



MK™ 2-Component Dispenser

TS408 HM-101

A 2-component pneumatic bead dispenser for 50mL cartridges.

Quick cartridge exchange for efficient working

Simple dispensing one hand speed adjustment

Reinforced nylon handle compact and lightweight



Model shown: TS408 HM-101 50mL

Product advantages

- Quick cartridge exchange
- One hand pressure adjustment
- Anti-drip function
- Reinforced nylon handle
- Warranty up to 2 years*

Customer benefits

- For efficient working
- Simple dispensing, effective working
- Clean application
- Compact and lightweight
- Gives you long worry free performance

Applications



Bonding

Product by range



*Effective 1st July 2018

The **MK TS408 HM-101** is part of a range of pneumatic dispensers. Designed for use with low viscosity sealants and adhesives.

Specifications

- Lightweight: 0.73kg / 1.6lbs
- Dispenser Length: 184mm / 7.2in
- Maximum Thrust: 1.3kN
- Maximum Pneumatic Pressure: 8bar / 116psi
- Air Consumption: 40 litres/min
- Handle Material: Reinforced Nylon
- Cartridge Holder Material: Reinforced Nylon
- Tool Component Approvals: CE
- Cartridge Capacity: 50mL (1.8oz)
- Cartridge Ratio: 10:1
- Standard Color: Black
- Customized versions on demand

Dimensions

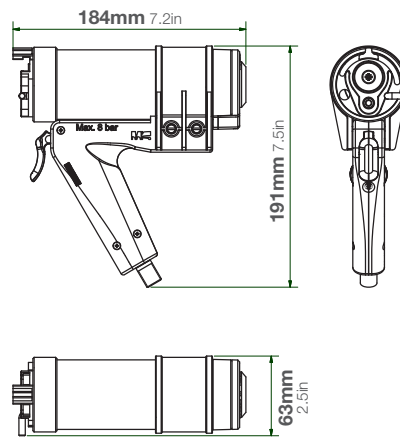

Part number:

DP2 50-16-300

Article number:

151886

Packaging:

1 per Box

Matching MIXPAC™ side-by-side cartridges



BS-System
50mL / 10:1 PP/PBT

Compatible side-by-side cartridges



Plastic cartridge
50mL / 10:1

10:1	mm	inch
a	101.8	4.0
b	Ø 25.9	Ø 1.0
c	Ø 8.1	Ø 0.3

Conversion kits

Matching accessories