

# MIXPAC™ Systems for Adhesives

## 2-Component Dispensers



Innovation in Application



# Overview

# Dispenser Systems

The Mixpac **DS Manual Dispenser**  
for 50 and 75mL BS-System Cartridges



The Mixpac **DM2X Manual Dispenser**  
for 200 and 400mL C, F, and BlueLine-System Cartridges



The Mixpac **DMA/DMB Manual Dispenser**  
for 50 and 75mL A and B-System Cartridges



The Mixpac **DP2X Pneumatic Dispenser**  
for 200 and 400mL C, F, and  
BlueLine-System Cartridges

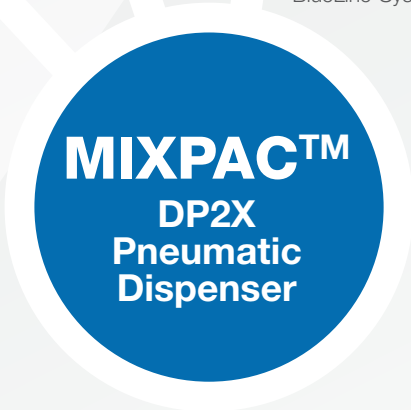



## Table of Contents 2 Component Dispensers

MIXPAC™ <b>DMA/DMB</b> .....	4
MIXPAC™ <b>DS</b> .....	6
MIXPAC™ <b>DM2X 200</b> .....	8
MIXPAC™ <b>DM2X 400</b> .....	10
MIXPAC™ <b>DP2X 200</b> .....	12
MIXPAC™ <b>DP2X 400</b> .....	14
MIXPAC™ <b>Accessories and Spare Parts</b> .....	16

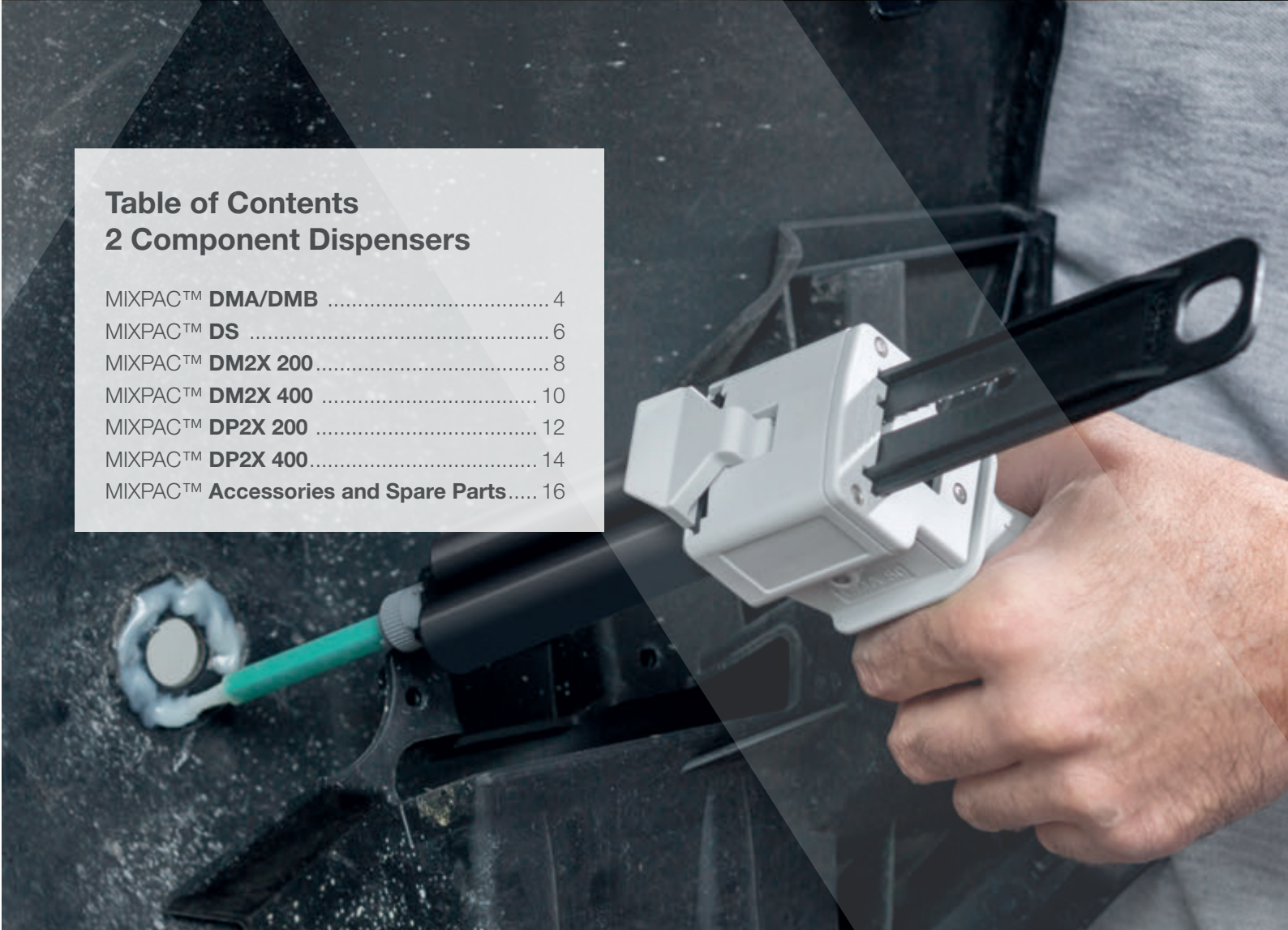



# MIXPAC™ DMA/DMB

50/75mL Cartridge Dispenser for A and B System

### Cartridge Support

Flap designed for maximum cartridge support and for easy cartridge exchange



### Release Button

Easily accessible with one hand

### Trigger

Dual drive to ensure even high viscosity materials maintain their mixing ratio

### Ergonomic Handle

For maximum comfort

## Features

- Exchangeable plunger system
- Allotted surface for logo
- Ergonomically designed

## Benefits

- Can be quickly converted into all 50mL and 75mL ratios for A and B systems
- The tool can be customized
- For comfortable and long working times

## Applications



Bonding



Sealing



Repair

## Product by range

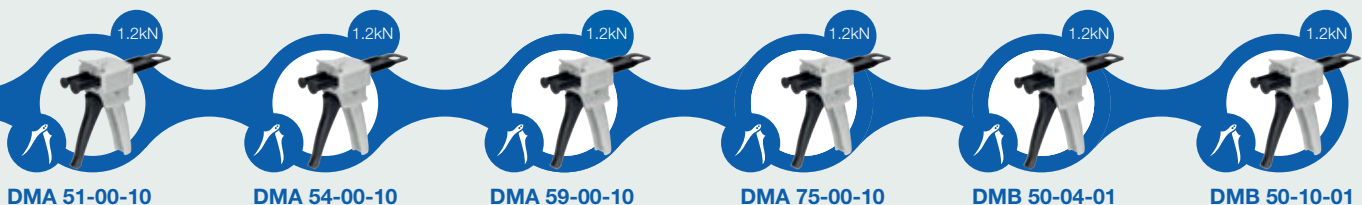

The **MIXPAC™ DMA/DMB** is a manual lightweight and sturdy 2-component dispenser designed for easy handling and precise dispensing.

### Specifications

- Weight 184g / 0.41lbs
- Length: 109mm / 4.3in
- Tool material: PP & reinforced nylon
- Cartridge capacity: 50/75mL
- Cartridge ratio: 1:1/2:1/4:1/10:1

### Dimensions

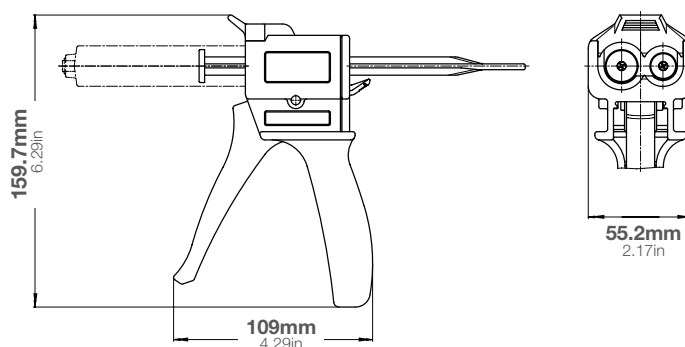

Part number:	Article number:	Ratio			
		1:1	2:1	4:1	10:1
DMA 51-00-10	101875	✓	✓		
DMA 54-00-10	101883	✓	✓	✓	
DMA 59-00-10	112790	✓	✓		✓
DMA 75-00-10	111746	✓			
DMB 50-04-01	116795			✓	
DMB 50-10-01	116794				✓

### Packaging:

Packed individually 64 units per master carton (50ml)  
Packed individually 32 units per master carton (75ml)

### Matching MIXPAC™ side by side cartridges

#### A-System



**A-System**  
50mL / 1:1 PP/PA



**A-System**  
50mL / 2:1 PP/PA



**A-System**  
50mL / 4:1 PP/PA



**A-System**  
50mL / 10:1 PP/PA/PBT



**A-System**  
75mL / 1:1 PP

#### B-System



**B-System**  
50mL / 1:1 PP/PA/PBT



**B-System**  
50mL / 2:1 PP/PA



**B-System**  
50mL / 4:1 PP/PBT



**B-System**  
50mL / 10:1 PP/PBT

### Conversion kits

PLA 050-01, PLA 050-04, PLA 050-10, PLA 075-01, PLB 50-04, PLB 50-10, See page page 16.

### Matching accessories

All accessories are displayed on page page 16.



# MIXPAC™ DS

## 50/75mL Cartridge Dispenser for BS-System

### Cartridge Support

Flap designed for maximum cartridge support and for easy cartridge exchange



**Release Button**  
Easily accessible with one hand

### Trigger

Dual drive to ensure even high viscosity materials maintain their mixing ratio

**Ergonomic Handle**  
For maximum comfort

### Features

- Dedicated tool for 1:1/2:1 ratios
- 4:1 and 10:1 plunger systems
- Allotted surface for logo
- Ergonomically designed

### Benefits

- No plunger change needed
- For easy ratio conversion
- The tool can be customized
- For comfortable and long working times

### Applications



Bonding



Sealing



Repair

### Product by range



DS 51-04-00

DS 51-10-00

DS 53-01-00

DS 75-10-00

DS 77-01-00

The **MIXPAC™ DS** is a manual lightweight and sturdy 2-component dispenser designed for easy handling and precise dispensing.

### Specifications

- Weight 215g / 0.47lbs
- Length: 109mm / 4.3in
- Tool material: PPO & reinforced nylon
- Cartridge capacity: 50-75mL
- Cartridge ratio: 1:1/2:1/4:1/10:1

### Dimensions

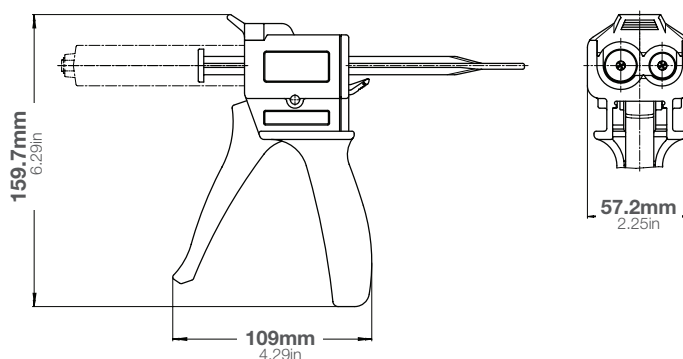

Part number:	Article number:	Ratio			
		1:1	2:1	4:1	10:1
DS 51-04-00	109146			✓	
DS 51-10-00	101929				✓
DS 53-01-00	101934	✓	✓		
DS 75-10-00	115676				✓
DS 77-01-00	110938	✓			

### Packaging:

Packed individually 64 units per master carton (50mL)  
Packed individually 32 units per master carton (75mL)

### Matching MIXPAC™ cartridges

#### BS-System



**BS-System**  
50mL / 1:1 PP/PA



**BS-System**  
50mL / 2:1 PP



**BS-System**  
50mL / 4:1 PP/PBT



**BS-System**  
50mL / 10:1 PP/PBT



**BS-System**  
75mL / 1:1 PP



**BS-System**  
75mL / 10:1 PBT

### Conversion kits

PLS 053-01, PLS 051-04, PLS 051-10, PLS 075-10,  
PLS 077-01, See page page 16.

### Matching accessories

All accessories are displayed on page page 16.



# MIXPAC™ DM2X 200

## 200mL Cartridge Dispenser

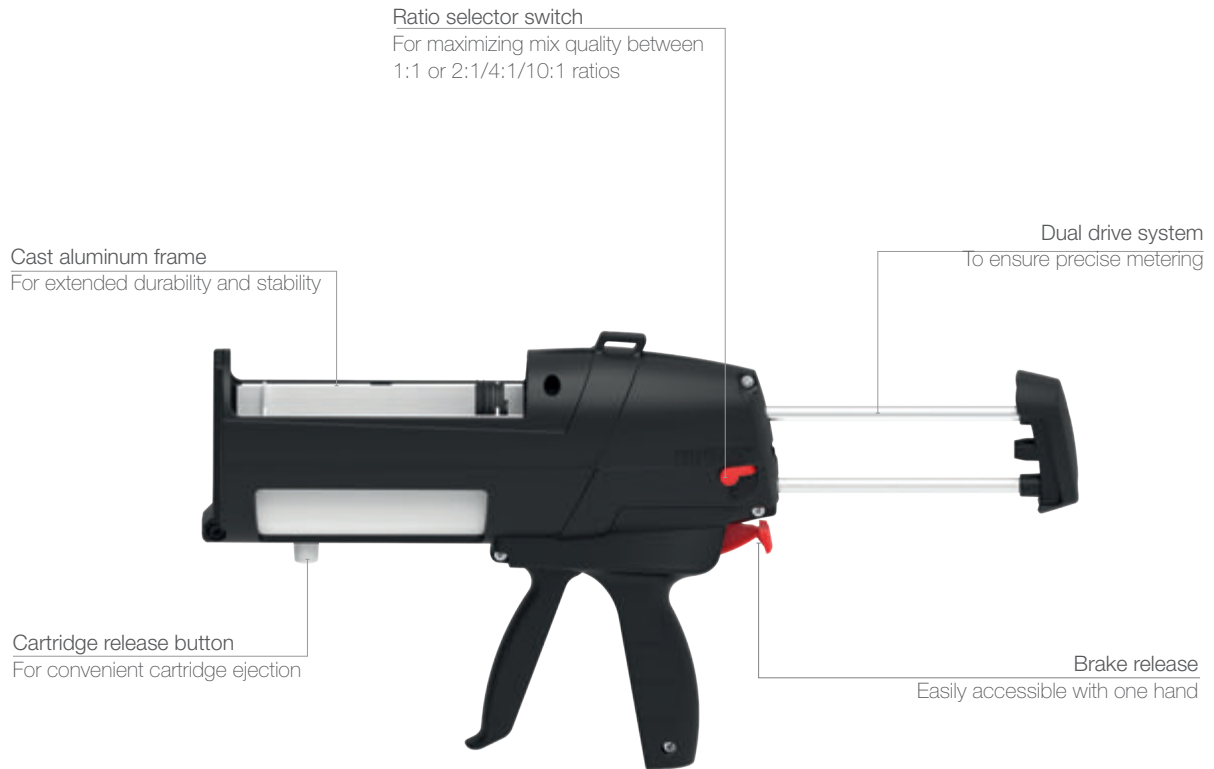

### Features

- Universal conversion kits with interchangeable cartridge trays and plungers
- High thrust ratio
- Ergonomically designed

### Benefits

- Quick ratio exchange and use with DM2X and DP2X tools
- Easy to dispense high viscosity products
- Maximum comfort and fatigue-free operation

### Applications

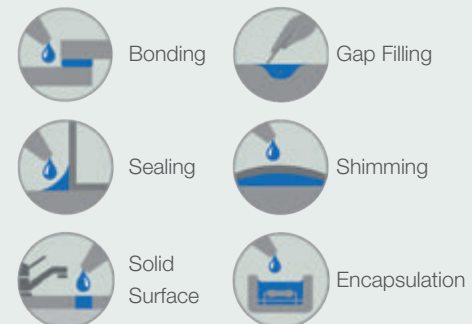

### Product by range





The **DM2X 200** is a manual dispenser for accurate metering with precise and consistent results.

### Specifications

- Weight 1.60kg / 3.53lbs
- Length: 324mm / 12.7in
- Maximum Thrust: 5.2kN
- Thrust ratio: 22:1
- Tool material: cast aluminum
- Cartridge capacity: 200mL
- Cartridge ratio: 1:1 / 2:1 / 4:1 / 10:1

### Dimensions

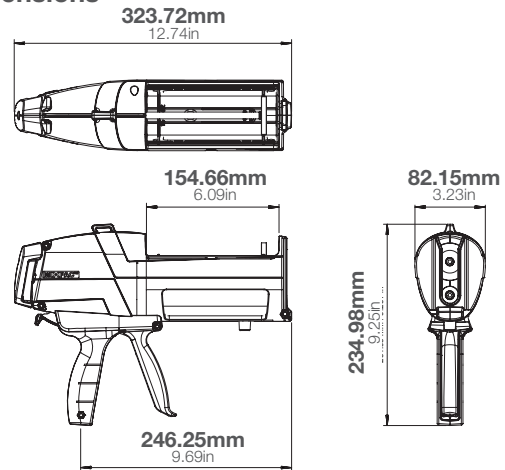

### Packaging:

Packed individually 1 unit per master carton

Part number:	Article number:	Ratio			
		1:1	2:1	4:1	10:1
DM2X 200-01-52-01	165803	✓	✓		
DM2X 200-04-52-01	165804			✓	
DM2X 200-10-52-01	165805				✓

### Matching MIXPAC™ side-by-side cartridges

#### C-System / F-System

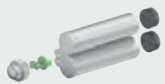

C-System / F-System  
200mL / 1:1 PP/PA

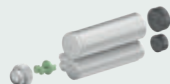

C-System / F-System  
200mL / 2:1 PP/PA

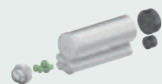

C-System / F-System  
200mL / 4:1 PP/PBT



C-System / F-System  
200mL / 10:1 PP/PBT

### Conversion kits

CKX 200-01-01, CKX 200-04-01, CKX 200-10-01

### Matching accessories

All accessories are displayed on page page 16.



# MIXPAC™ DM2X 400

## 400mL Cartridge Dispenser

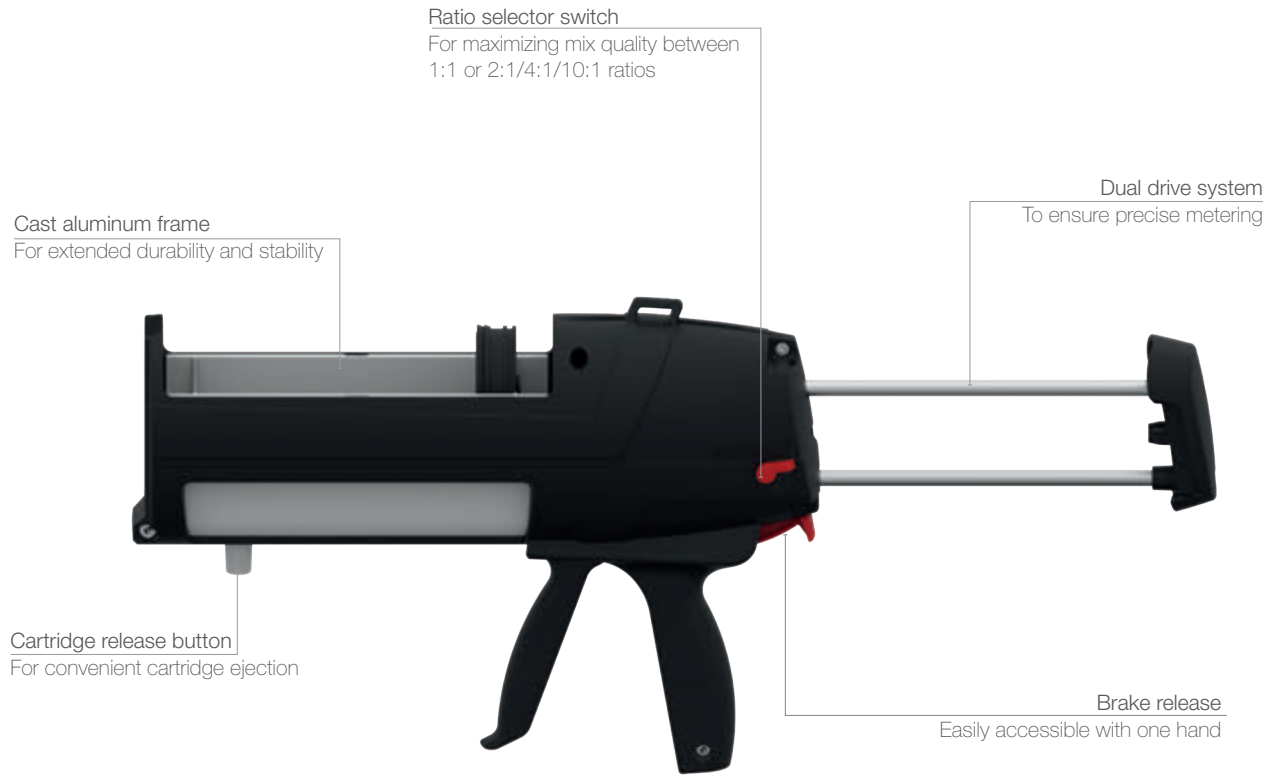

### Features

- Universal conversion kits with interchangeable cartridge trays and plungers
- High thrust ratio
- Ergonomically designed

### Benefits

- Quick ratio exchange and use with DM2X and DP2X tools
- Easy to dispense high viscosity products
- Maximum comfort and fatigue-free operation

### Applications

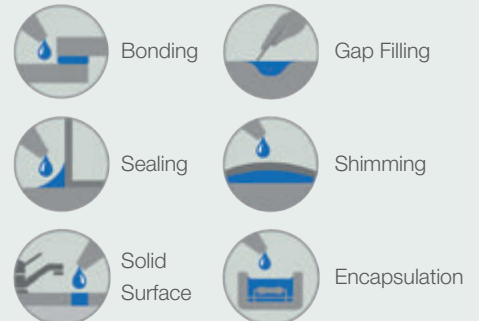

### Product by range

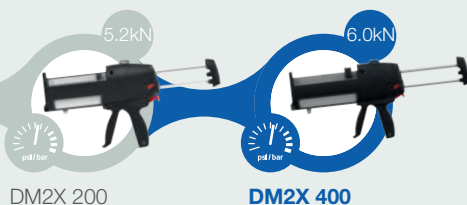

The **DM2X 400** is a manual dispenser for accurate metering with precise and consistent results.

### Specifications

- Weight: 1.93kg / 4.24lbs
- Length: 366mm / 14.4in
- Maximum thrust: 6.0kN
- Thrust ratio: 35:1
- Tool material: cast aluminum
- Cartridge capacity: 400mL
- Cartridge ratio: 1:1/2:1/4:1/10:1

### Dimensions

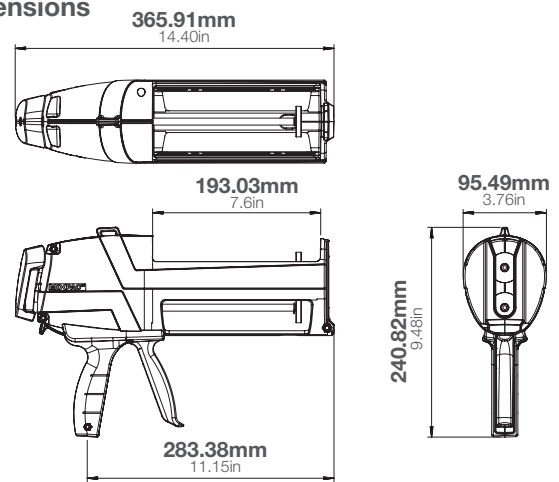

### Packaging:

Packed individually 1 unit per master carton

Part number:	Article number:	Ratio			
		1:1	2:1	4:1	10:1
DM2X 400-01-60-01	165807	✓	✓		
DM2X 400-04-60-01	165808			✓	
DM2X 400-10-60-01	165809				✓

### Matching MIXPAC™ side-by-side cartridges

#### C-System / F-System



C-System / F-System  
400mL / 1:1 PP/PA/PBT

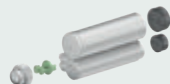

C-System / F-System / BlueLine  
400mL / 2:1 PP/PA

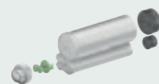

C-System / F-System  
400mL / 4:1 PP/PBT



C-System / F-System / BlueLine  
400mL / 10:1 PP/PBT

### Conversion kits

CKX 400-01-01, CKX 400-04-01, CKX 400-10-01

### Matching accessories

All accessories are displayed on page page 16.



# MIXPAC™ DP2X 200

## 200mL Cartridge Dispenser

### Indicator Rod

To quickly see how much material is remaining in the cartridge

Mounting Hook  
To suspend dispenser

### Cartridge Release Button

Conveniently located to provide easiest cartridge ejection

Plunger Retract Button  
Easily accessible with one hand

### Trigger

Ergonomic trigger for comfort

Regulator  
Adjust output force

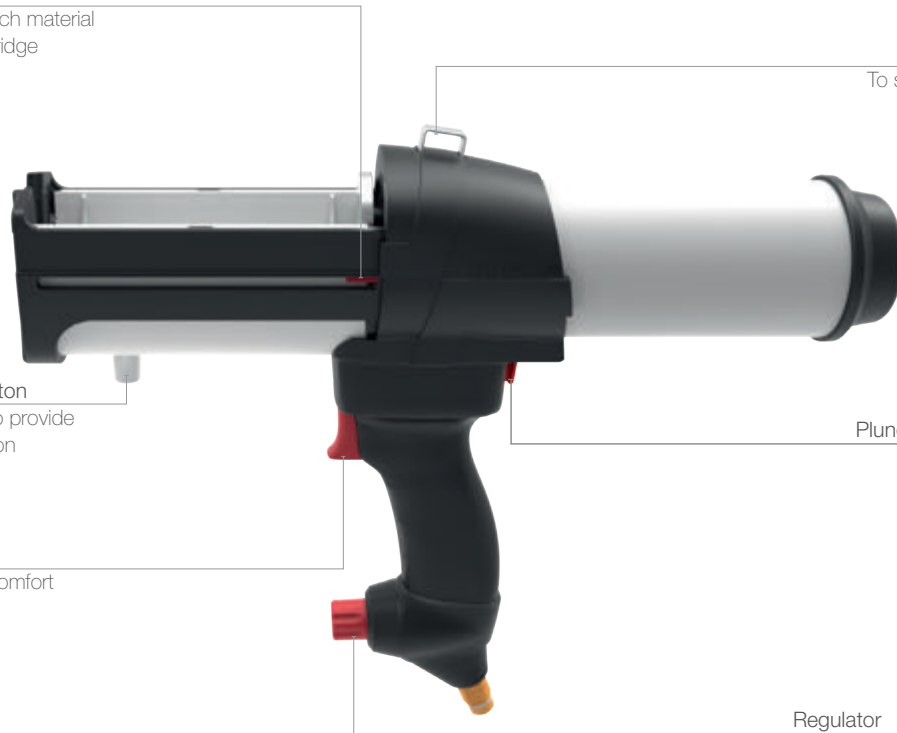

### Features

- Universal conversion kits with interchangeable cartridge trays and plungers
- Quick Exhaust
- Integrated anti-drip feature
- Ergonomically designed

### Benefits

- Quick ratio exchange and use with DM2X and DP2X tools
- High precision and dispensing accuracy
- No oozing or dripping
- Fatigue free operation for longer periods of time

### Applications

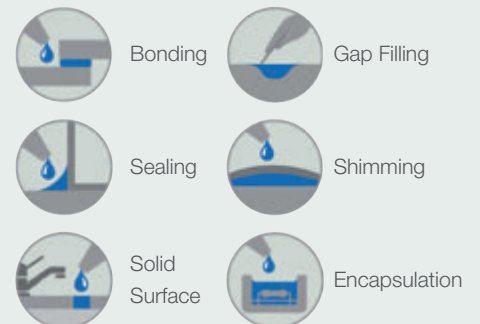

### Product by range

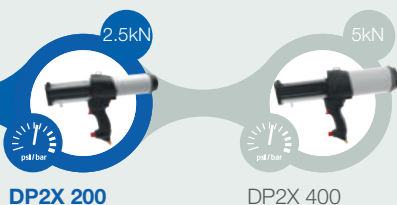

The **DP2X 200** is a pneumatic dispenser for achieving accurate and repeatable results while working with maximum comfort.

### Specifications

- Weight 1.76kg / 3.87lbs
- Length: 406mm / 15.9in
- Maximum Thrust: 2.5kN
- Tool material: cast aluminium and reinforced nylon
- Cartridge capacity: 200mL
- Cartridge ratio: 1:1 / 2:1 / 4:1 / 10:1
- Air inlet: 1/4in NPT
- Max operating pressure: 6.8 bar / 100 psi

### Dimensions

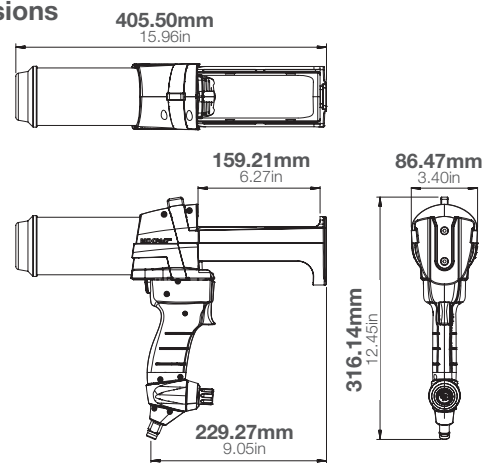

### Packaging:

Packed individually 1 unit per master carton

Part number:	Article number:	Ratio			
		1:1	2:1	4:1	10:1
DP2X 200-01-25-01	165860	✓	✓		
DP2X 200-04-25-01	165861			✓	
DP2X 200-10-25-01	165862				✓

### Matching MIXPAC™ side-by-side cartridges

#### C-System / F-System

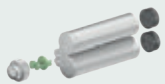

C-System / F-System  
200mL / 1:1 PP/PA

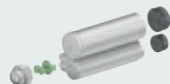

C-System / F-System  
200mL / 2:1 PP/PA

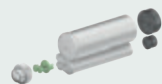

C-System / F-System  
200mL / 4:1 PP/PBT



C-System / F-System  
200mL / 10:1 PP/PBT

### Conversion kits

CKX 200-01-01, CKX 200-04-01, CKX 200-10-01

### Matching accessories

All accessories are displayed on page page 16.



# MIXPAC™ DP2X 400

## 400mL Cartridge Dispenser

### Indicator Rod

To quickly see how much material is remaining in the cartridge

Mounting Hook  
To suspend dispenser

### Cartridge Release Button

Conveniently located to provide easiest cartridge ejection

Plunger Retract Button  
Easily accessible with one hand

### Trigger

Ergonomic trigger for comfort

Regulator  
Adjust output force



### Features

- Universal conversion kits with interchangeable cartridge trays and plungers
- Quick exhaust
- Integrated anti-drip feature
- Ergonomically designed

### Benefits

- Quick ratio exchange and use with DM2X and DP2X tools
- High precision and dispensing accuracy
- No oozing or dripping
- Fatigue free operation for longer periods of time

### Applications

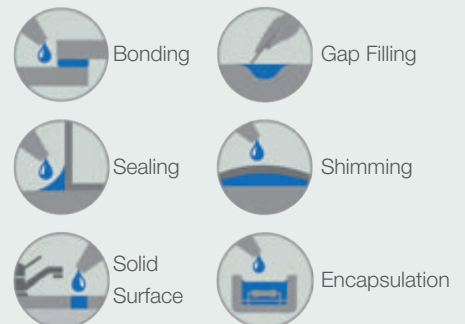

### Product by range

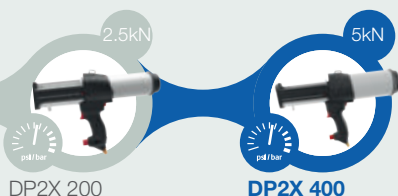

The **DP2X 400** is a pneumatic dispenser for achieving accurate and repeatable results while working with maximum comfort.

### Specifications

- Weight 2.66kg / 5.87lbs
- Length: 486mm / 19.1in
- Maximum Thrust: 5.0kN
- Tool material: cast aluminium and reinforced nylon
- Cartridge capacity: 400mL
- Cartridge ratio: 1:1 / 2:1 / 4:1 / 10:1
- Air inlet: 1/4in NPT
- Max operating pressure: 6.8 bar/100 psi

### Dimensions

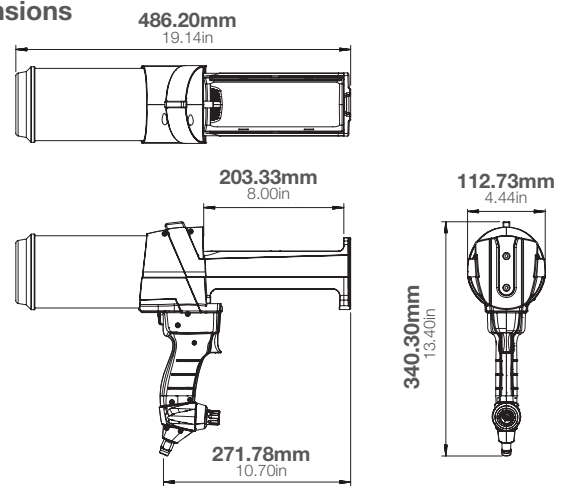

### Packaging:

Packed individually 1 unit per master carton

Part number:	Article number:	Ratio			
		1:1	2:1	4:1	10:1
DP2X 400-01-50-01	165864	✓	✓		
DP2X 400-04-50-01	165865			✓	
DP2X 400-10-50-01	165866				✓

### Matching MIXPAC™ side-by-side cartridges

#### C-System / F-System



C-System / F-System  
400mL / 1:1 PP/PA



C-System / F-System / BlueLine  
400mL / 2:1 PP/PA

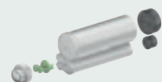

C-System / F-System  
400mL / 4:1 PP/PBT



C-System / F-System / BlueLine  
400mL / 10:1 PP/PBT





### Conversion kits

CKX 400-01-01, CKX 400-04-01, CKX 400-10-01

### Matching accessories

All accessories are displayed on page page 16.

# MIXPAC™ Accessories and Spare Parts

	Name/Description	ID	Article number	Compatible with
	<b>Plunger</b> for DS Dispensers	103160	PLS 053-01	<b>DS</b>
		113018	PLS 051-04	
		100385	PLS 051-10	
		113559	PLS 077-01	
		115587	PLS 075-10	
	<b>Plunger</b> for DMA/DMB Dispensers	109018	PLA 050-01	<b>DMA/DMB</b>
		109020	PLA 050-04	
		103114	PLA 050-10	
		109193	PLA 075-01	
		128083	PLB 50-04	
128084	PLB 50-10			
	<b>Conversion Kit 200mL</b> Cartridge tray A and B plunger disks	165834	CKX 200-01-01	<b>DM2X 200</b> <b>DP2X 200</b>
		165835	CKX 200-04-01	
		165836	CKX 200-10-01	
	<b>Conversion Kit 400mL</b> Cartridge tray A and B plunger disks	165839	CKX 400-01-01	<b>DM2X 400</b> <b>DP2X 400</b>
		165840	CKX 400-04-01	
		165841	CKX 400-10-01	





SULZER

SULZER

## Innovation in Application

**Headquarters / Europe**

Sulzer Mixpac Ltd  
Ruetistrasse 7  
9469 Haag, Switzerland  
phone +41 81 414 70 00  
mixpac@sulzer.com  
www.sulzer.com

**USA, South America,  
Canada and Mexico**

Sulzer Mixpac USA Inc.  
8 Willow St.  
Salem, NH 03079, USA  
phone +1 603 893 2727  
mixpac@sulzer.com  
www.sulzer.com

**UK and Ireland**

Sulzer Mixpac (UK) Ltd.  
1 Tealgate, Charnham Park, Hungerford  
Berkshire, RG17 0YT, United Kingdom  
phone: +44 1488 647 800  
coxsales@sulzer.com  
www.coxdispensers.com

**Asia Pacific**

Sulzer Mixpac China  
68 Bei Dou Lu, Minhang  
Shanghai 200245, China  
phone +86 21 6430 68 68  
mixpac@sulzer.com  
www.sulzer.com